

OPTION: ACCESSORIES- WASHR & NUT

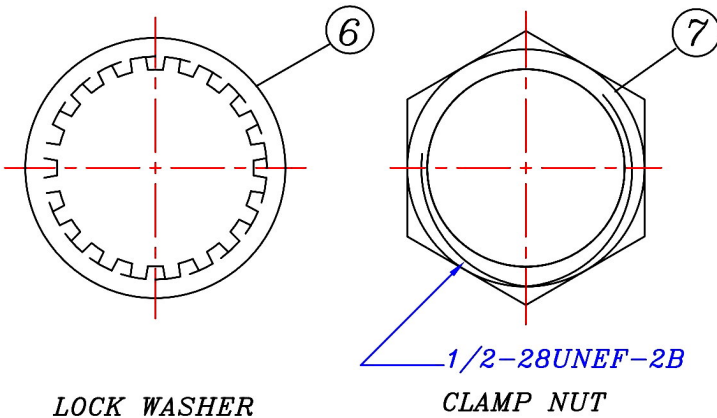

LOCK WASHER

CLAMP NUT

P/N: C0401-RNABM000R => Without ACCESSORIES
P/N: C0401-RNABM001R => With ACCESSORIES

RECOMMENDED MOUNTING HOLE
MAXIMUM PANEL THICKNESS: 5.5MM

RECOMMENDED PC BOARD LAYOUT
WITHOUT MOUNTING POSTS

MATERIAL & FINISH

- ① CENTER CONTACT : PHOSPHOR BRONZE, GOLD PLATING
- ② BODY : ZINC ALLOY, NICKEL PLATING
- CT ③&⑧ INSULATOR : PE-606
- ④ MOUNTING POST : BRASS, TIN PLATING
- ⑤ SOLDER TAIL : COPPER WIRE, TIN PLATING
- ⑥ WASHER : STEEL, NICKEL PLATING
- ⑦ NUT : BRASS, NICKEL PLATING

RoHS Compliant		HSM 玄茂科技股份有限公司 HSUAN MAO TECHNOLOGY CO., LTD.	
APPD. 核准 HELEN	SCALE 比例 参考	TOLERANCE 容許公差 X ± 0.5 XX ± 0.3 XXX ± 0.2 ANGLES ± 3 DEG	PART NAME 品名 BNC CONNECTOR RIGHT ANGLE TYPE WITHOUT FILTER 50ohms BODY HEIGHT: 12.9mm METAL BODY NICKEL PLATING ROHS
DWG. 製圖 ABBY	UNIT 單位 MM	SIZE 紙張尺寸 A 4	PART NO. 料號 C0401-RNABM00XR
DATE 製表日 2023/04/18	PAGE 張數 1 OF 1	REV. 版次 C	