

SECTION A-A

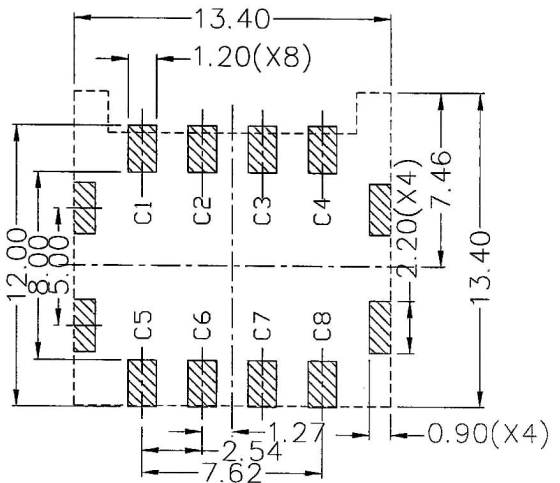

RECOMMENDED P.C.B LAYOUT
COMPONENT SIDE(TOLERANCE ±0.05)

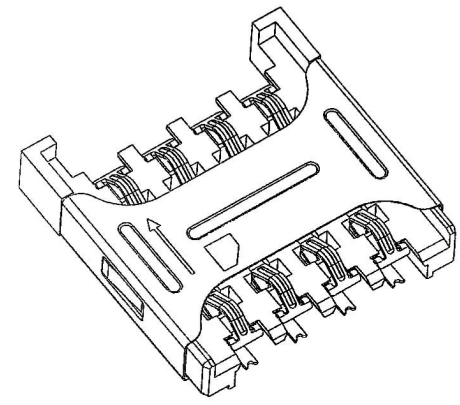

MATERIALS:
 HOUSING: HI-TEMP. PLASTIC (UL 94V-0), BLACK
 TERMINAL: PHOSPHOR BRONZE, GOLD PLATED OVER ALL
 SHELL: STAINLESS STEEL SMT AREA GOLD PLATED
SPECIFICATION:
 CURRENT RATING: 0.5 AMP MAX
 DIELECTRIC WITHSTANDING: 500V AC FOR ONE MINUTE
 CONTACT RESISTANCE: 30m OHMS MAX
 INSULATION RESISTANCE: 1000M OHMS MIN AT DC 500V
 OPERATION TEMPERATURE: -25°C~+85°C

PIN NO.	PIN NAME
C1	Supply Voltage Vcc
C2	Reset (RST)
C3	Clock(CLK)
C4	N/A
C5	Ground
C6	Programming Voltage Vpp
C7	I/O
C8	N/A

RoHS Compliant		玄茂科技股份有限公司 HSUAN MAO TECHNOLOGY CO., LTD.	
APPD. 核准		TOLERANCE .X±0.30 X'± 3° .XX±0.20 X'± 3° .XXX±0.10 .XX'± 3°	PART NAME 品名 MICRO SIM CARD CONNECTOR 8PIN SMT 90° TYPE H=2.4mm W/O LOCATING PEG & W/O SWITCH GOLD FLASH PLATING REEL PACKING BLACK COLOR ROHS
DWG. 製圖	Betty	SCALE 比例 參考	PART NO. 料號 C0628-08BAAGBRR
DATE 製表日	2018/02/01	UNIT 單位 MM	
		PAGE 張數 1 OF 1	
		REV. 版次 B	