

N:Pin

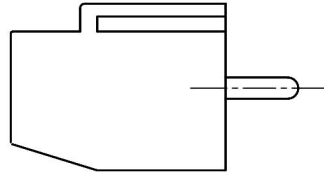

- MATERIAL
 SCREWS : M2.5 STEEL ZINC PLATED
 WIRE GUAR : PHOSPHOR BRONZE NICKEL PLATING
 HOUSING : PA66 UL94V-0
 SOLDER PIN : BRASS TIN PLATING

- ELECTRICAL
 RATED VOLTAGE : 300V
 RATED CURRENT : 10A
 CONTACT RESISTANCE : 20mΩ
 INSULATION RESISTANCE : 5000Ω /1000V
 WITHSTANDING VOLTAGE : AC2000V/1Min
 WIRE RANGE : 20~14AWG 2.5mm²

- MECHANICAL
 TEMP.RANGE : -40℃~+105℃
 MAX SOLDERING : +250℃, FOR 5 SEC.
 TORQUE : 0.4Nm (3.6Lb.in)
 STRIP LENGTH : 6-7mm

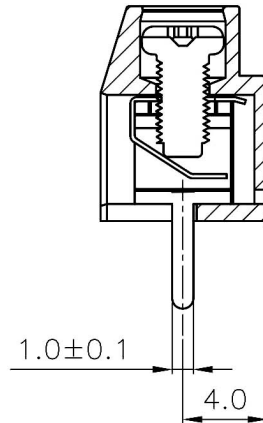
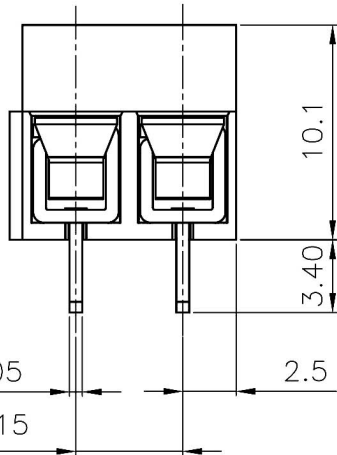

A-A

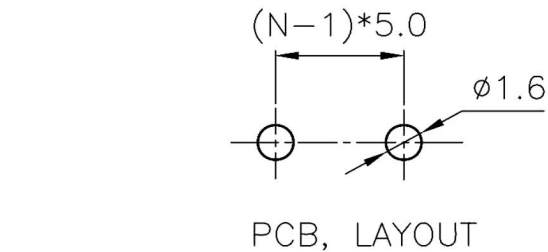

PCB, LAYOUT

RoHS Compliant		HSM 玄茂科技股份有限公司 HSUAN MAO TECHNOLOGY CO., LTD.	
APPD. 核准		TOLERANCE X ±0.60 .XX ±0.38 XX ±0.25 X ±5° .XX ±2°	PART NAME 品名 5.0mm TERMINAL BLOCK XXPin STRAIGHT TYPE H:10mm WITH LEAF SPRING SUITABLE FOR 14~20AWG GREEN INSULATOR ROHS
DWG. 製圖	Betty	SCALE 比例 參考	PART NO. 料號 C0926-XXSRTE00R
DATE 制表日 2014/10/31	UNIT 單位 MM	SIZE. 紙張尺寸 A4	
	PAGE 張數 1 OF 1	REV. 版次 B	