

NOTES:

1. Rating: UL: 300V 15A
IEC: 600V 18A
PITCH: 5.00mm
2. Insulation Withstands Voltage:
AC 1500 V at 1 minute
3. Insulation Resistance:
500MΩ or more at DC500V
4. Using Temperature Range:
-40°C~+105°C
5. Screw Torque Value: 0.5N·m
6. Suitable Electric Wire:
UL: AWG 30~12 IEC: 0.2~4mm² (sol)
0.2~2.5mm² (str)
7. RoHS Compliance

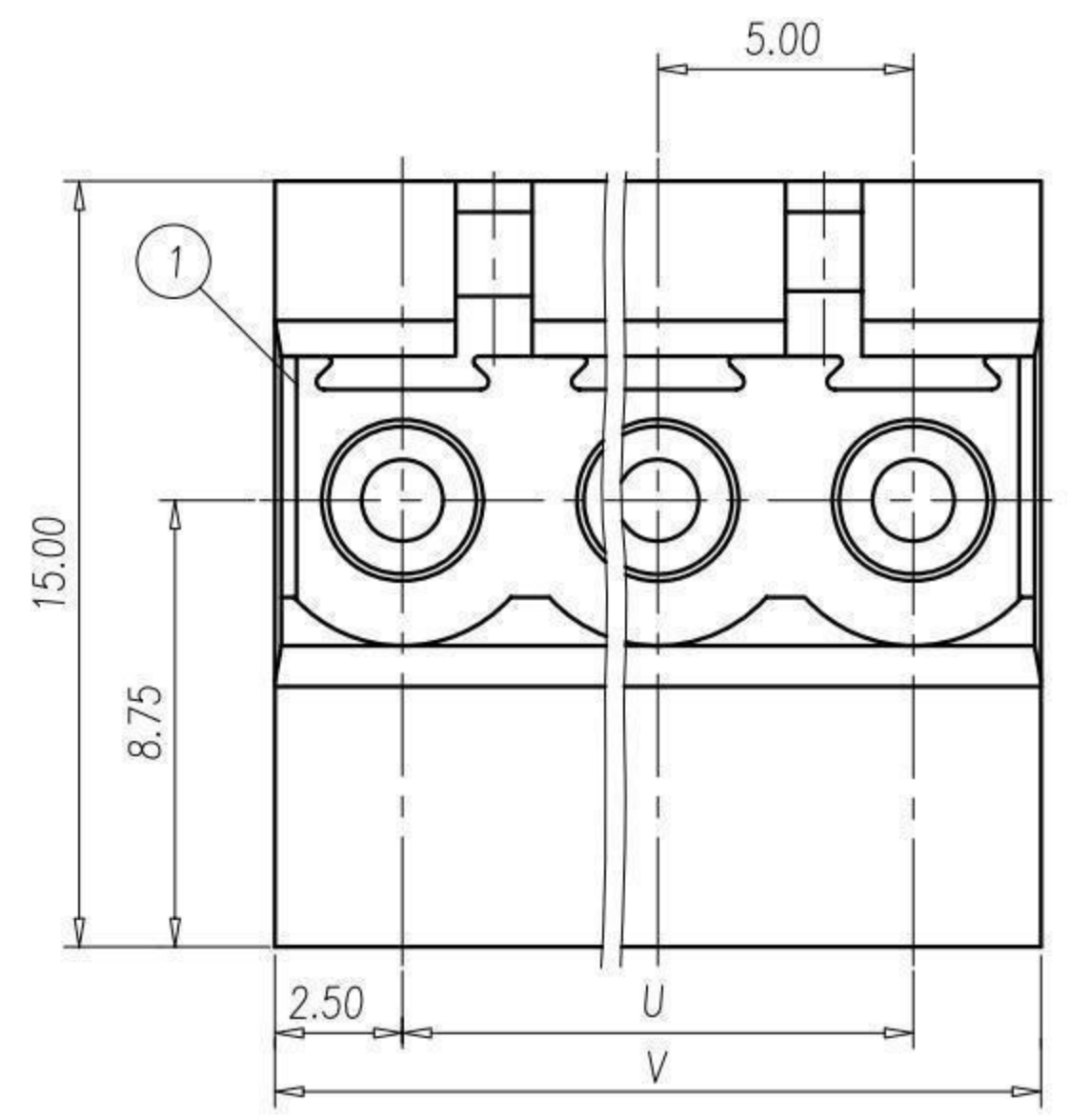
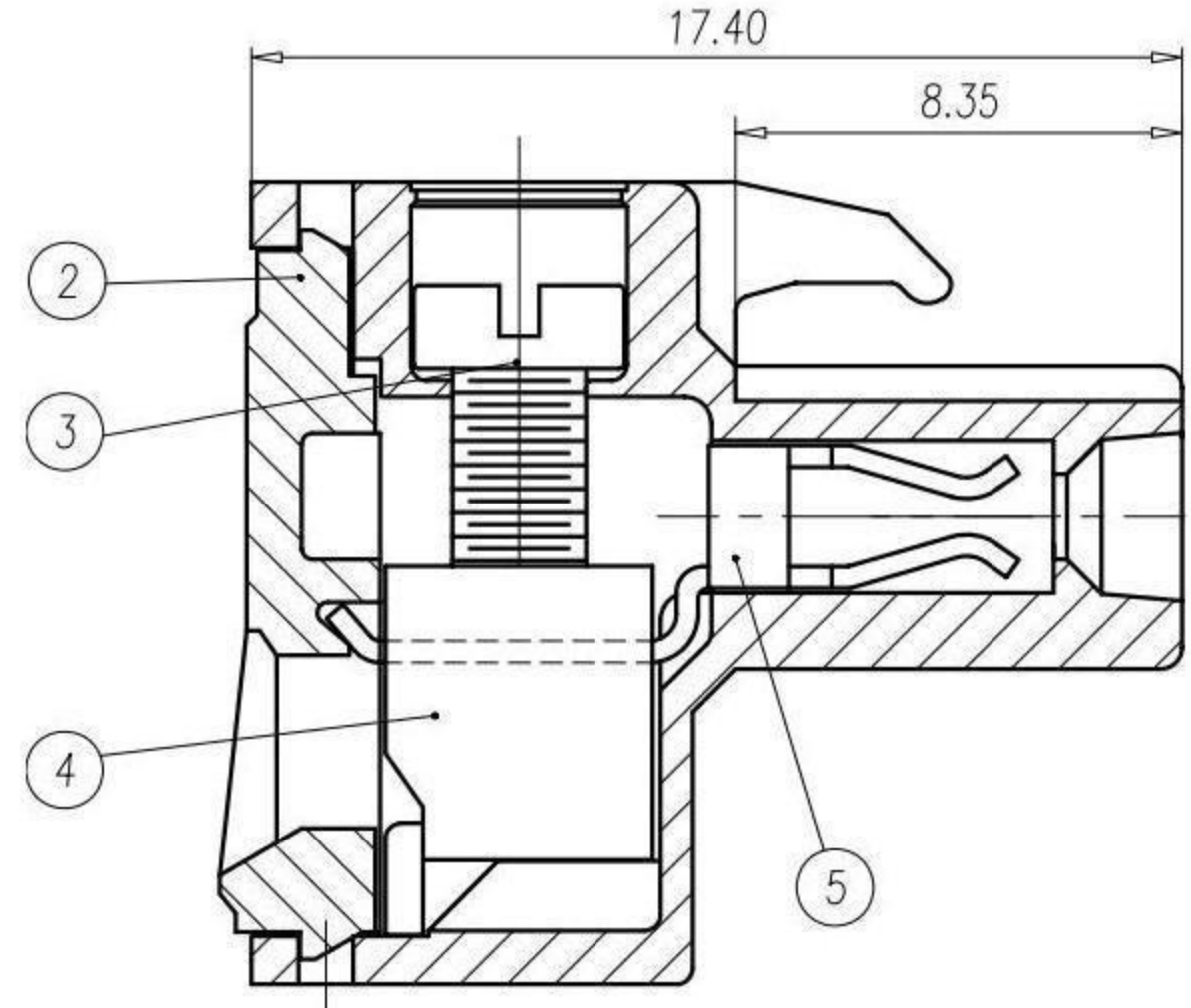
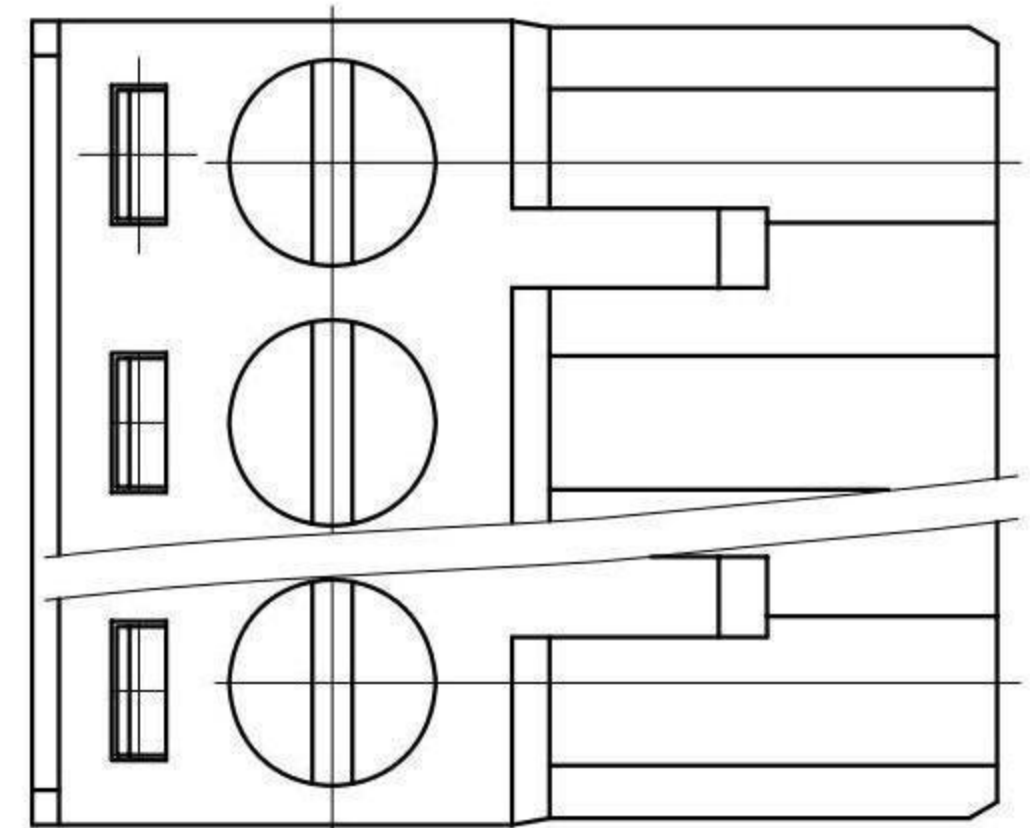

5	CLAMP	COPPER-ALLOY	Tin Plated
4	WIRE CAGE	STEEL	M2.5/Zn Plated
3	SCREW	STEEL	M2.5/Zn Plated
2	SIDE COVER	PA66	UL94-V0 GREEN
1	HOUSING	PA66	UL94-V0 GREEN
ITEM	NAME OF PART	MATERIAL	NOTES

Normal Geometric Tolerancing				
	-	//	≡	⊥
0 to 100	0.2		0.3	0 to 10 0.2
over 100 to 150	0.3			over 10 0.3
over 150	0.5			
Total Pitch Tolerances		Normal dimension Tolerances		
0<U≤30	±0.20	0~30	±0.25	
30<U≤53	±0.25	over 30~53	±0.30	
53<U≤70	±0.30	over 53~70	±0.35	
70<U≤90	±0.35	over 70~90	±0.44	
90<U≤115	±0.44	over 90~115	±0.55	
115<U≤150	±0.55	over 115~150	±0.70	
150<U≤200	±0.70	over 150~200	±0.85	
200<U≤250	±0.85	over 200~250	±1.00	
250<U≤320	±1.00	over 250~320	±1.20	

P	2	3	4	5	6	7	8	9	10	11	12	13
U	5.0	10.0	15.0	20.0	25.0	30.0	35.0	40.0	45.0	50.0	55.0	60.0
V	10.0	15.0	20.0	25.0	30.0	35.0	40.0	45.0	50.0	55.0	60.0	65.0
P	14	15	16	17	18	19	20	21	22	23	24	
U	65.0	70.0	75.0	80.0	85.0	90.0	95.0	100.0	105.0	110.0	115.0	
V	70.0	75.0	80.0	85.0	90.0	95.0	100.0	105.0	110.0	115.0	120.0	

RoHS Compliant

HSM 玄茂科技股份有限公司

HSUAN MAO TECHNOLOGY CO., LTD.

APPD. 核准 BETTY	SCALE 比例 参考	TOLERANCE 容許公差 .0 ± .00 ± ANG. ±	PART NAME 品名 5.0mm TERMINAL BLOCK H=15mm XXPIN SUITABLE FOR 12~30AWG WITHOUT EAR GREEN COLOR ROHS
DWG. 製圖 KAREN	UNIT 單位 MM	SIZE 紙張尺寸 A4	PART NO. 料號 C0944-XXWNA3TE0R
DATE 制表日 2014/07/17	PAGE 張數 1 OF 1	REV. 版本 A	