

1 2 3 4 5 6 7 8

A

A

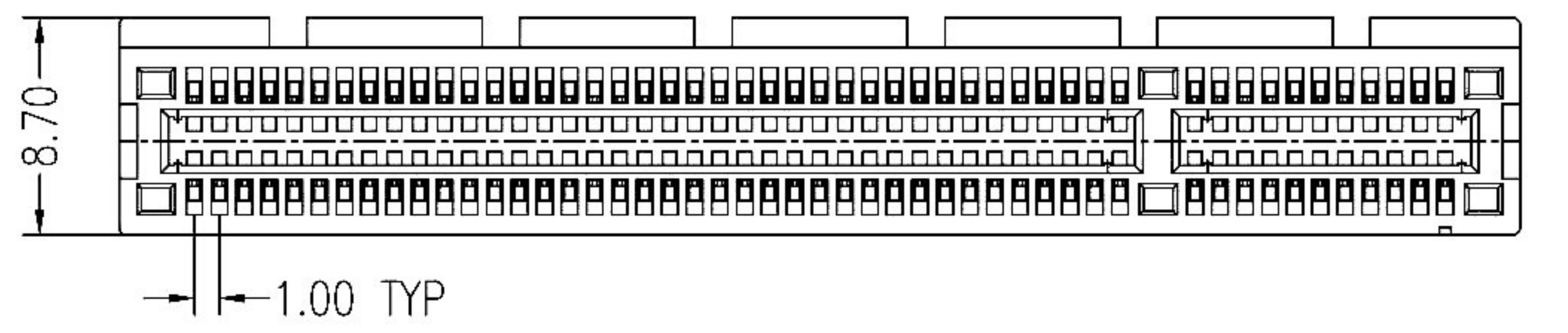

B

B

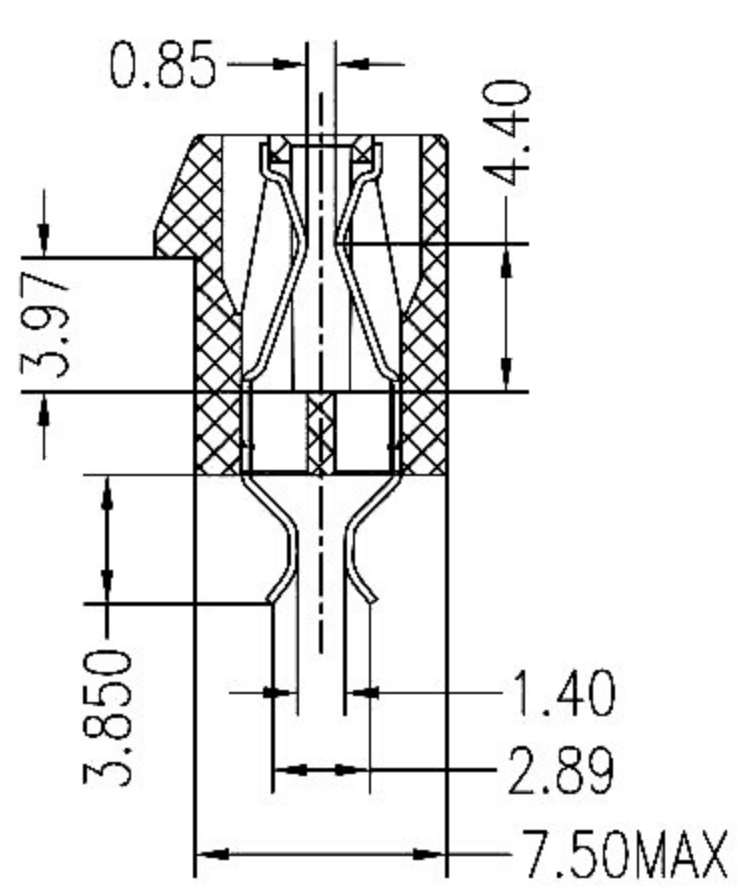
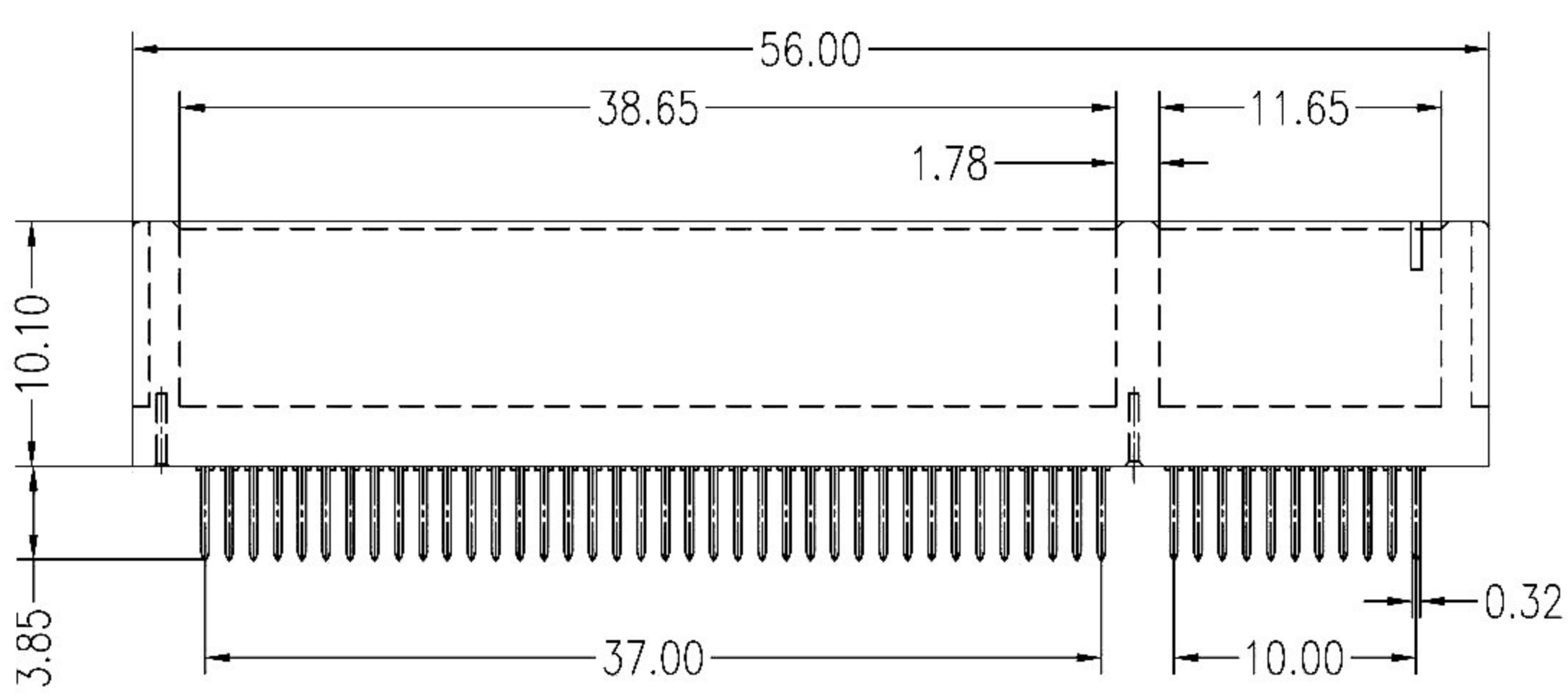

NOTES:

- 1. Material:
 Housing: Nylon9T+30%G.F, UL 94V-0 Rated.
 Color: Black.
 Contact: Brass.
 Plating: Gold Plating over Nickel on Contact Area.
 Tin Plating on Solder Tail.

C

C

- 2. Mechanical:
 Insertion Force: 1.15N Max per Contact Pair.
 Withdrawal Force: 0.15N Min per Contact Pair.
 Contact Retention Force: 4.9N Min per Contact.

D

D

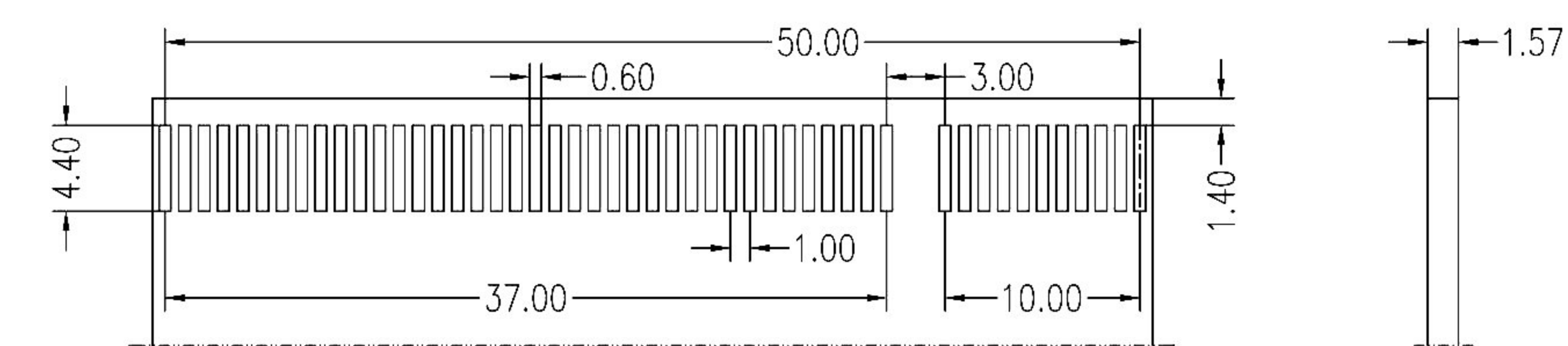

P.C.B. Layout For Straddle

- 3. Electrical Specification:
 Current Rating: 1.1 Ampere.
 Contact Resistance: 30mΩ Max.
 Insulation Resistance: 1000MΩ Min.
 Dielectric Withstanding Voltage: 500 VAC.

E

E

- 4. Environmental:
 Operating Temperature: -55°C to +105°C

F

F

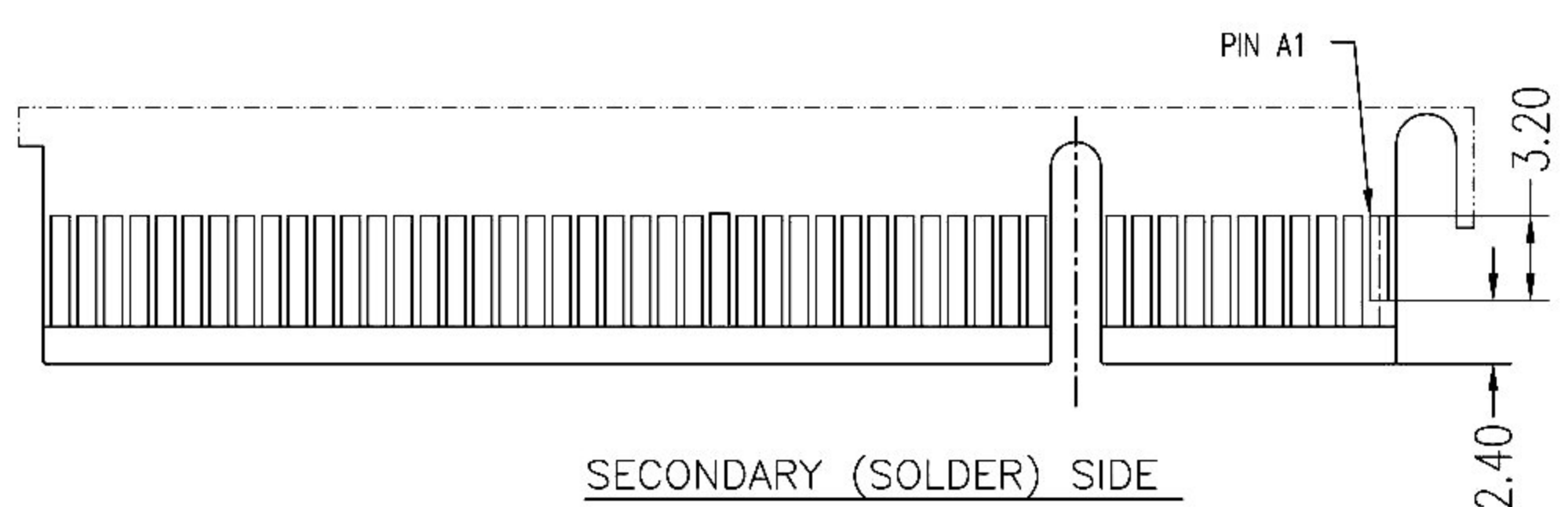

SECONDARY (SOLDER) SIDE

G

G

RoHS Compliant	HSM 玄茂科技股份有限公司 HSUAN MAO TECHNOLOGY CO., LTD.	
-------------------	--	--

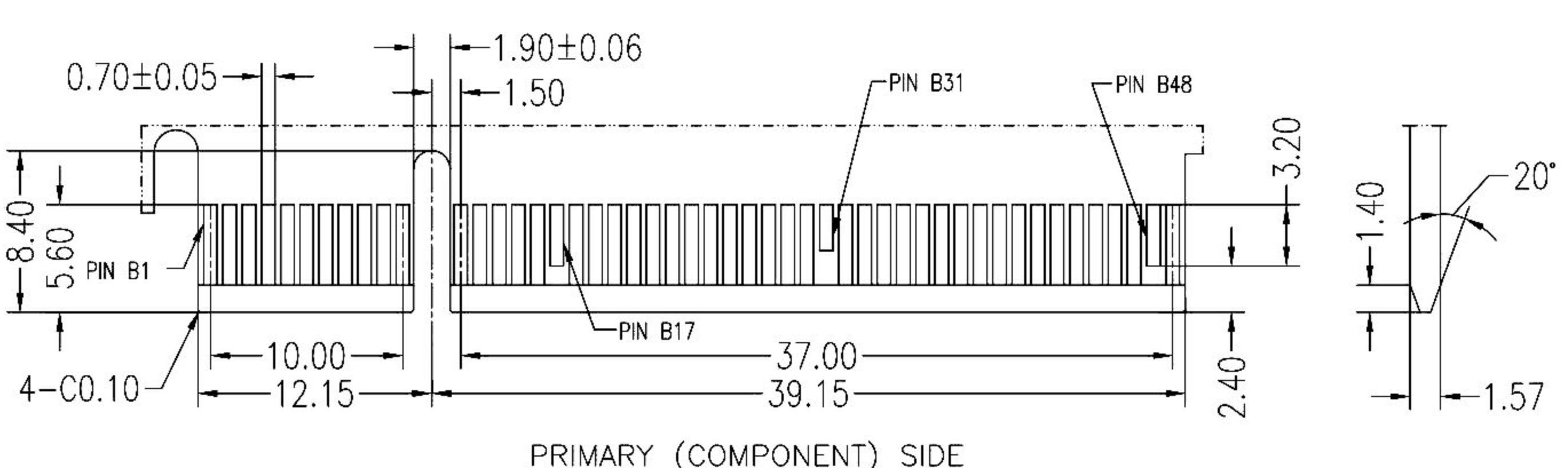

PRIMARY (COMPONENT) SIDE

APPD. 核准 HELEN	 TOLERANCE 容許公差 X ± .38 .XX ± .25 .XXX ± .20 ANG ± 3°	PART NAME 品名 1.0mm PCI Express Straddle SMT Type 98Pin Insulator Material:Nylon 9T Terminal:Brass Selective Gold Plating Tray Packing ROHS
DWG. 製圖 ABBY		
DATE 制表日 2019/11/20	SCALE 比例 參考 UNIT 單位 MM PAGE 張數 1 OF 1	REV. 版次 A
PART NO. 料號 C3623-98BBSBH0R		

H

H

1 2 3 4 5 6 7 8