

**SCHEMATIC**

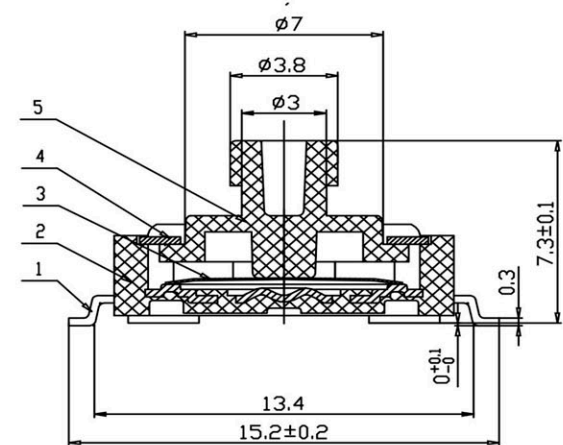
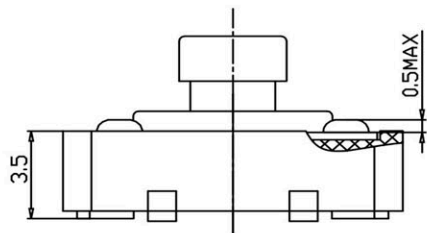
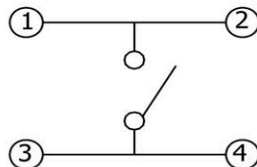

**General specifications**

Circuit : PUSH ON  
 Rating : D.C. 12V 50mA  
 Contact R.[max] : 50mΩ (initial)  
 Insulation R.[min] : D.C. 100V 100MΩ  
 Withstand VOL. : A.C. 250V 1minute  
 Operating force : 160±50g  
 Operation life : 80,000 CYCLES

**P.C.B. LAYOUT**

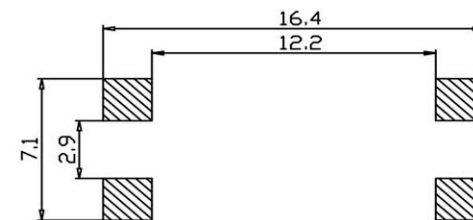

**MATERIAL SPECIFICATIONS**

ITEM	PART NAME	MATERIAL	QTY	FINISH
1	TERMINAL	Brass	1	Silver Plating
2	CASE	FR52	1	Black
3	CONTACT	Phosphor bronze	1	Contact Side Silver Plating
4	COVER	SPCC-SD	1	CuSn Plated
5	STEM	FR52	1	Black

RoHS  
Compliant

**HSM** 玄茂科技股份有限公司  
**HSUAN MAO TECHNOLOGY CO., LTD.**

APPD. 核准		TOLERANCE 容許公差	PART NAME 品名
DWG. 製圖		SCALE 比例	
DATE 制表日	UNIT 單位	SIZE. 紙張尺寸	PART NO. 料號
2015/4/13	M M	A 4	
	PAGE 張數	REV. 版本	
	1 OF 1	A	