

ITEM	DESC	Q'TY	MATERIALS	TREATMENT
1	TERMINAL	1	PHOSPHORBRONZE	WITH SILVER PLATING
2	BASE	1	HIGH-TEMP THERMOPLASTIC	MOLDED BLACK
3	TAPE	1	KAPTON	-
4	STEM	1	KAPTON	-
5	CONTACT	3	STAINLESS STEEL	WITH SILVER CLADDING

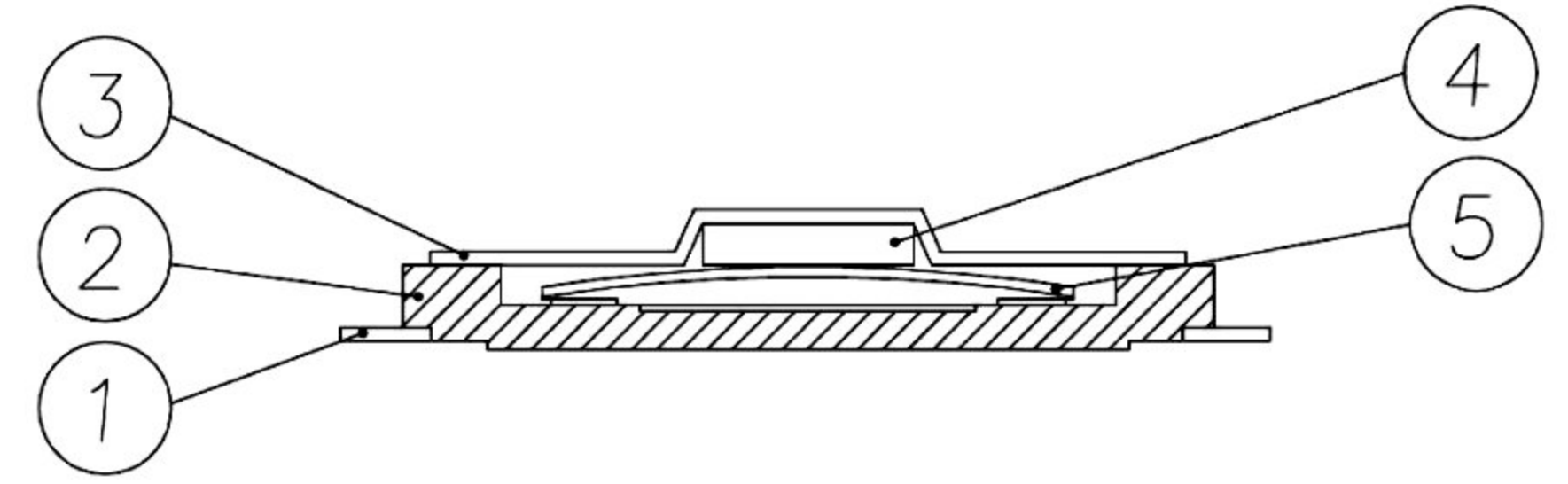

NOTES:

- ALL DIMENSIONS ARE IN MILLIMETERS.
- GENERAL TOLERANCES ± 0.1 mm.
- SOLDER THICKNESS: 0.08mm.

SPECIFICATIONS:

- RATING: 50mA, DC 12V.
- LIFE: 300,000 STEPS.
- INITIAL CONTACT RESISTANCE: 500m Ω Max.
- DIELECTRIC STRENGTH: AC 250V 1 MINUTE.
- INSULATION RESISTANCE: 100M Ω Min.
- OPERATING TEMPERATURE: -40°C to +85°C.
- OPERATING FORCE: 180gf

OPERATING FORCE(PUSH)-TRAVEL CHART

		玄茂科技股份有限公司 HSUAN MAO TECHNOLOGY CO., LTD.	
APPD. 核准 HELEN		TOLERANCE 容許公差 .0 ±0.1 .00 ± ANG ±	PART NAME 品名 2.0X3.0mm TACT SWITCH SMT TYPE KONB HEIGHT: 0.6mm OPERATING FORCE: 180g FILM+REEL PACKING ROHS
DWG. 製圖 ABBY	SCALE 比例 參考	UNIT 單位 MM	SIZE 紙張尺寸 A4
DATE 制表日 2018/12/03	PAGE 張數 1 OF 1	REV. 版次 A	PART NO. 料號 C8722-EF000000R