

NOTE:

1. ALL DIMENSIONS ARE IN MILLIMETERS, BRACKETED DIMENSIONS ARE IN INCHES.
2. GENERAL TOLERANCES MAX.±0.20mm.

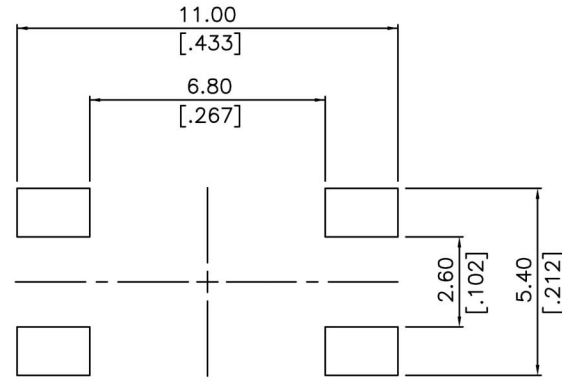
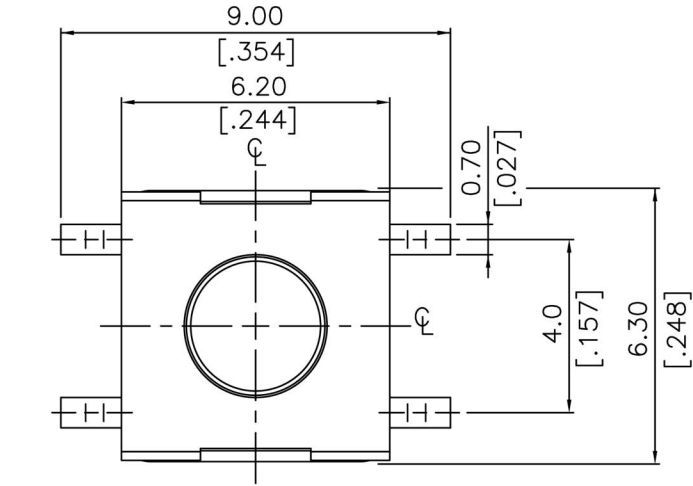

(SCALE 8:1)

P.C.B. LAYOUT

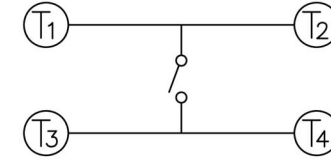

CIRCUIT DIAGRAM

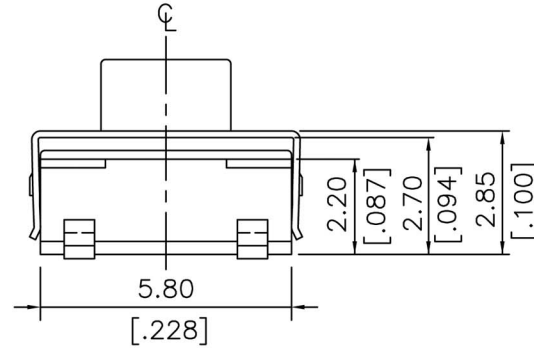
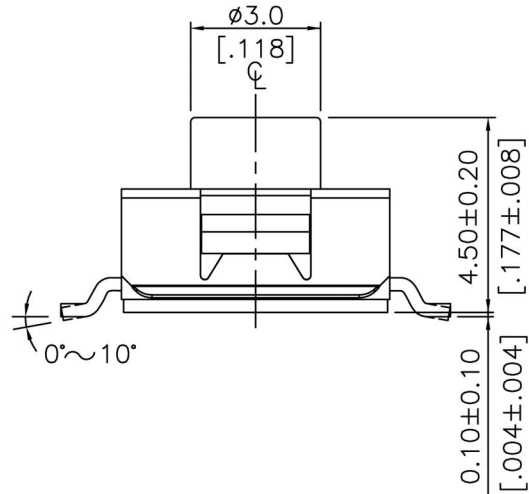
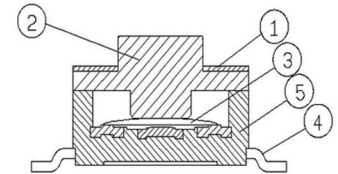

ITEM	DESC.	Q'TY	MATERIALS	TREATMENT
1.	COVER	1	STAINLESS STEEL	NONE
2.	SEALED RUBBER	1	SILICONE RUBBER	NONE
3.	CONTACT	1	STAINLESS STEEL	WITH SILVER CLADDING
4.	TERMINAL	1	BRASS	WITH SILVER PLATING
5.	BASE	1	HIGH - TEMP THERMOPLASTIC NYLON UL 94V-0	MOLDED BLACK

RoHS Compliant **HSM 玄茂科技股份有限公司**
HSUAN MAO TECHNOLOGY CO., LTD.

APPD. 核准		TOLERANCE 容許公差	PART NAME 品名
DWG. 製圖		SCALE 比例	
DATE 制表日	UNIT 單位	SIZE. 紙張尺寸	TACT SWITCH SMT TYPE KONB HEIGHT:4.5mm
2019/01/28	PAGE 張數	REV. 版次	OPERATING FORCE:XXXgf ROHS
			PART NO. 料號
			C8723-DXXX0000R

A
B
C
D
E
F
G
H

A
B
C
D
E
F
G
H

1 2 3 4 5 6 7 8

1 2 3 4 5 6 7 8