

**NOTE:**

1. ALL DIMENSIONS ARE IN MILLIMETERS, BRACKETED DIMENSIONS ARE IN INCHES.
2. GENERAL TOLERANCES MAX.±0.20mm.

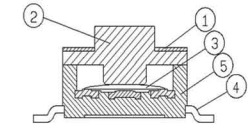
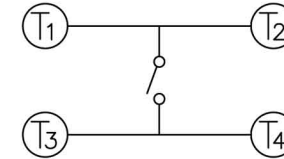
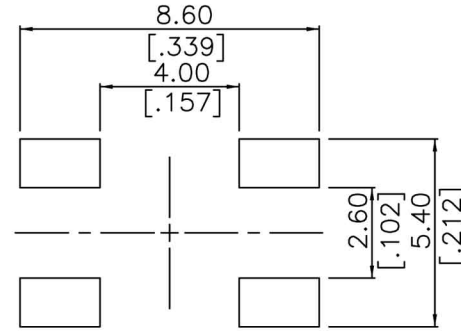
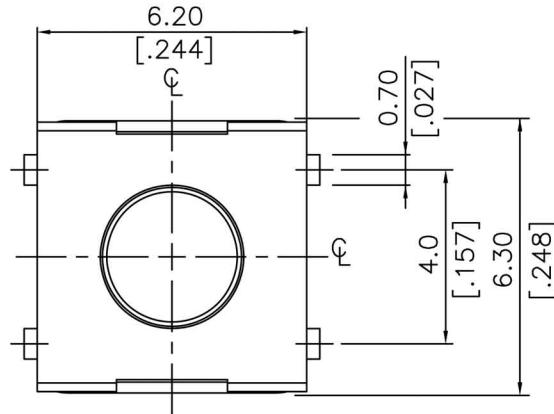

**P.C.B. LAYOUT SCALE 8:1**

**CIRCUIT DIAGRAM**

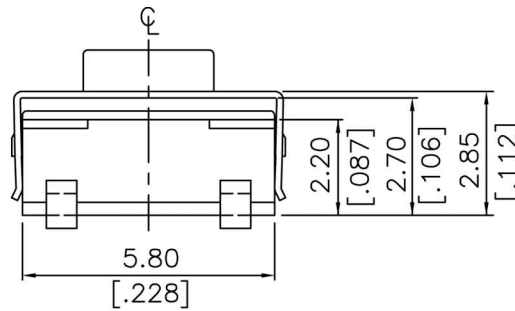
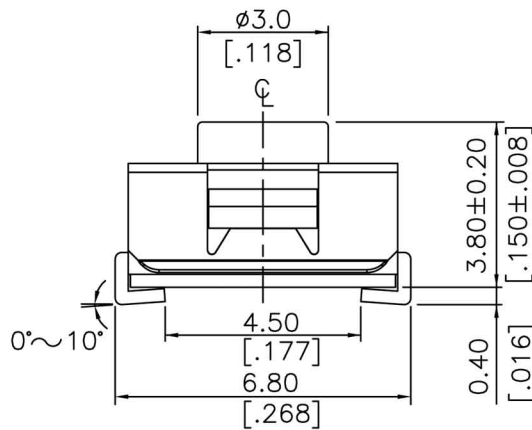

ITEM	DESC.	Q'TY	MATERIALS	TREATMENT
1.	COVER	1	STAINLESS STEEL	NONE
2.	SEALED RUBBER	1	SILICONE RUBBER	NONE
3.	CONTACT	1	STAINLESS STEEL	WITH SILVER CLADDING
4.	TERMINAL	1	BRASS	WITH SILVER PLATING
5.	BASE	1	HIGH - TEMP THERMOPLASTIC NYLON UL 94V-0	MOLDED BLACK

**RoHS Compliant**

**HSM 玄茂科技股份有限公司**  
**HSUAN MAO TECHNOLOGY CO., LTD.**

APPD. 核准		TOLERANCE 容許公差	PART NAME 品名
DWG. 製圖		SCALE 比例	
DATE 制表日	Hedy	UNIT 單位	PART NO.
2019/01/25		M M	
		PAGE 張數	
		1 / 1	
		REV. 版次	
		A	