

NO.	Part Name 品名	Q'TY 数量	Generic Class 材质
1	Base 底座	1	PBT
2	Case 盖片	1	PBT
3	Button 按钮	1	PBT
4	Spring Plate 弹片	1	C1720
5	Contact 接点	1	Silver alloy 银合金
6	Terminal 端子	3	C2680

1. Functional specification			
1.1 Specification Value	1A 125VAC/DC5V 30mA	1.4 Free Position (FP)	7.35±0.2 mm
1.2 Contact resistance	≤100mΩ (Initial value)	1.5 Operating Position (OP)	7.2±0.2mm
1.3 Operating Force (OF)	60±20gf		
2. Reliability parameter			
2.1 Mechanical life	1,000,000 CYCLES	2.5 Welding process	Hand soldering
2.2 Electrical life	10,000 CYCLES	2.6 Operating temperature	-25℃ ~ +65℃
2.3 Insulation resistance	≥100MΩ DC500V	2.7 Storage temperature	< 85%RH
2.4 Withstand voltage strength	AC500V 1 minute		

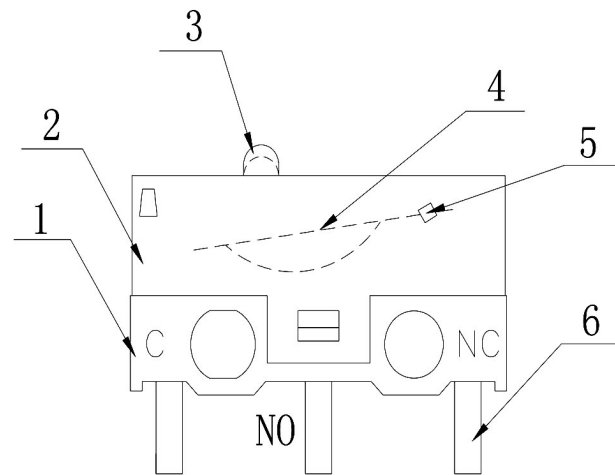
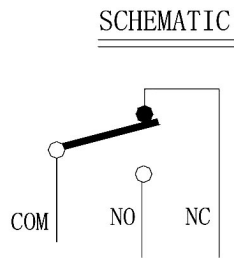

RoHS Compliant		玄茂科技股份有限公司 HSUAN MAO TECHNOLOGY CO., LTD.	
APPD. 核准	SCALE 比例 参考	TOLERANCE 容許公差 .0 ± 0.30 .00 ± 0.20 ANG. ± 3°	PART NAME 品名 5.08mm MICRO SWITCH 3PIN 1A 125VAC CIRCUIT TYPE:1P2T WITHOUT LEVER TYPE DIP LENGTH:3.3mm OPERATING FORCE:60±20gf ROHS
DWG. 製圖 Betty	UNIT 單位 M M	SIZE. 紙張尺寸 A 4	PART NO. 料號 C8802-01ANAB00R
DATE 製表日 2019/09/12	PAGE 張數 1 OF 1	REV. 版次 A	