

1 2 3 4 5 6 7 8

A

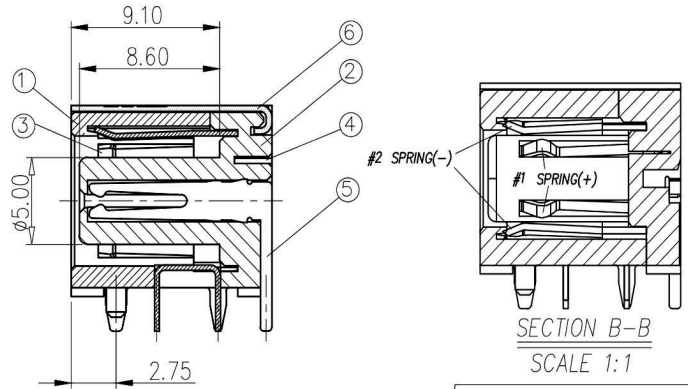
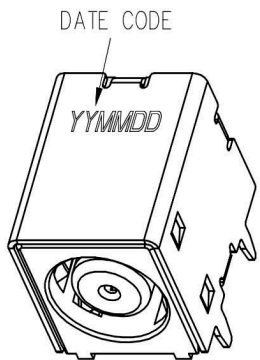

SECTION A-A  
SCALE 1:1

SECTION B-B  
SCALE 1:1

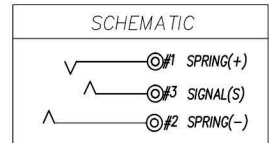

SPECIFICATIONS:  
 1. ELECTRICAL CHARACTERISTICS:  
 1-1. RATING: 30V 10A  
 1-2. CONTACT RESISTANCE: 30mΩ MAX.(INITIAL)  
 1-3. DIELECTRIC WITHSTANDING VOLTAGE: 500V AC FOR ONE MINUTE.  
 1-4. INSULATION RESISTANCE: 100MΩ MIN. MEASURED BY 500 VDC  
 2. MECHANICAL CHARACTERISTICS:  
 2-1. INSERTION FORCE : 3.0 KGF Max.  
 2-2. WITHDRAWAL FORCE : 0.35 KGF Min.  
 3. LIFE TEST: 5,000 CYCLES MIN.

B

C

D

E

F

G

H

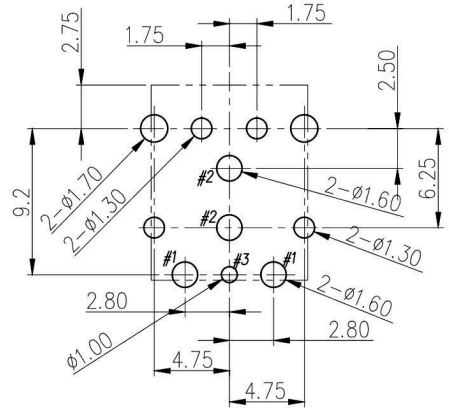
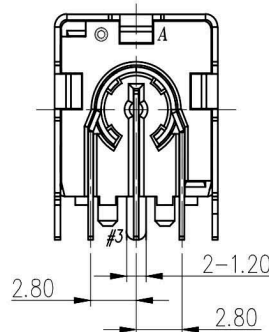
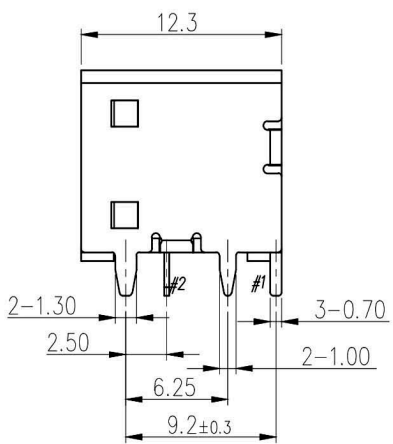
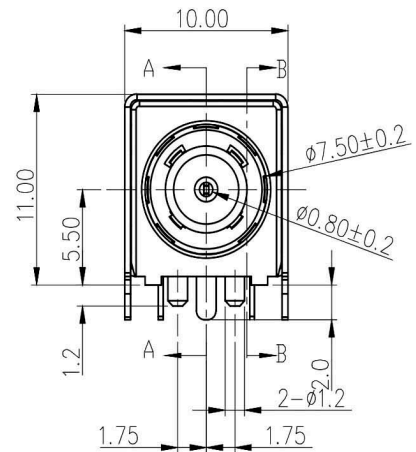

RECOMMENDED P.C.B LAYOUT  
TOP VIEW (TOLERANCE: ±0.05)

6	SHELL	1	BRASS 0.35T	Ni PLATED
5	SIGNAL (S)	1	COPPER ALLOY 0.3T	GOLD FLASH
4	CONTACT (+)	1	COPPER ALLOY 0.3T	GOLD FLASH
3	SPRING (-)	1	COPPER ALLOY 0.3T	GOLD FLASH
2	COVER	1	HIGH TEMP. THERMOPLASTIC	UL94V-0(BLACK)
1	HOUSING	1	HIGH TEMP. THERMOPLASTIC	UL94V-0(BLACK)
LTR	PART NAME	QTY	MATERIAL	REMARK

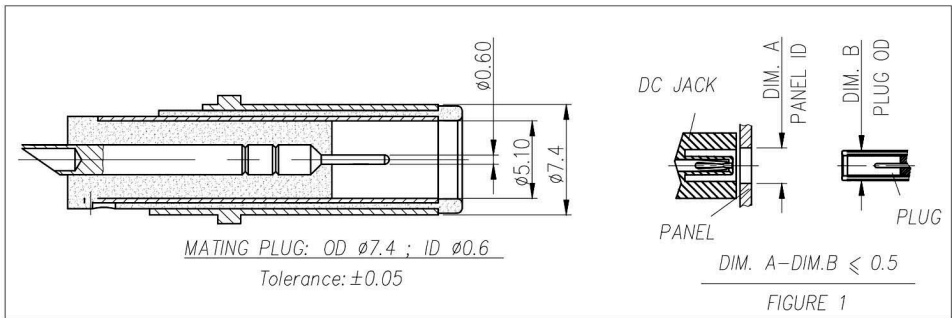

UNLESS OTHERWISE SPECIFIED, TOLERANCE ON DECIMAL: ±0.3

RoHS  
Compliant

**HSM** 玄茂科技股份有限公司  
**HSUAN MAO TECHNOLOGY CO., LTD.**

APPD. 核准	Betty	SCALE 比例 参考	TOLERANCE 容許公差 .0 ± .00 ± ANG. ±	PART NAME 品名 DC POWER JACK φ0.8mm GOLD FLASH PLATING WITH LOCATING PEG REEL PACKING BLACK INSULATOR ROHS
DWG. 製圖	DATE 制表日 2020/03/05	UNIT 單位 MM	SIZE. 紙張尺寸 A 4	PART NO. 料號 C9757-KGYBR000R
		PAGE 張數 1 OF 1	REV. 版次 A	

1 2 3 4 5 6 7 8