

1 2 3 4 5 6 7 8

A
B
C
D
E
F
G
H

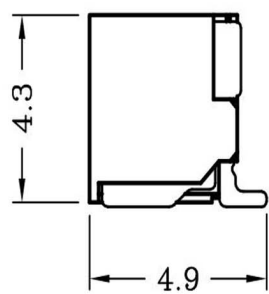
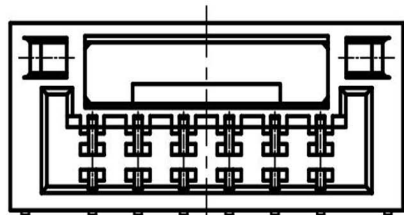

- SPECIFICATIONS
- ◆ Applicable Wire: AWG.#26~#30
 - ◆ Rated voltage: 50V DC/AC(rms)
 - ◆ Rated Current: 1A (AWG.#26)
 - ◆ Withstand voltage: 100V AC/min.
 - ◆ Working Temp : -25°C ~ +85°C
 - ◆ Insulation resistance: ≥100 MΩ
 - ◆ Contact resistance: ≤30 mΩ

- MATERIAL
- ◆ Insulator: PA9T, UL94-V0
 - ◆ Contact PIN: Phosphor Bronze
 - ◆ Solder tab: Phosphor Bronze

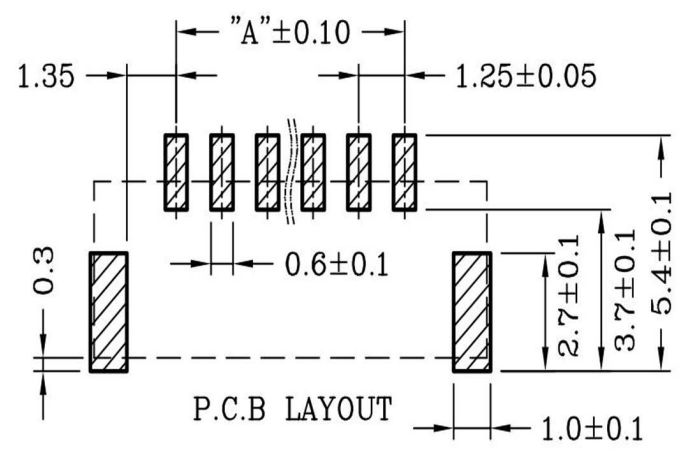
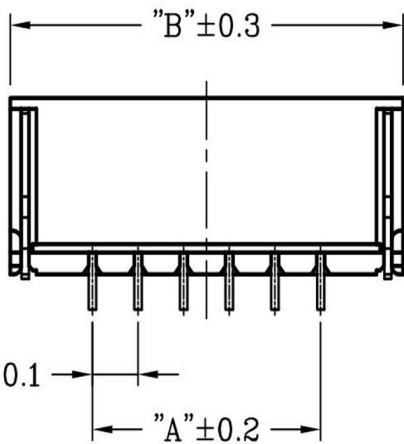

Poles	DIM.A	DIM.B
2P	1.25	5.75
3P	2.50	7.00
4P	3.75	8.25
5P	5.00	9.50
6P	6.25	10.75
7P	7.50	12.00
8P	8.75	13.25
9P	10.00	14.50
10P	11.25	15.75
11P	12.50	17.00
12P	13.75	18.25
13P	15.00	19.50
14P	16.25	20.75
15P	17.50	22.00

RoHS Compliant		玄茂科技股份有限公司 HSUAN MAO TECHNOLOGY CO., LTD.	
APPD. 核准	 SCALE 比例 參考 UNIT 單位 M M PAGE 張數 1 OF 1	GENERAL TOLERANCE	PART NAME 品名 JST GH1.25mm 1XXXP WAFER SMT RIGHT ANGLE TYPE TIN PLATING IVORY COLOR (NYLON9T UL94V-0) ROHS
DWG. 製圖 Betty		XX ± 0.40 X ± 0.30 X ± 0.25 XX ± 0.15	
DATE 制表日 2014/09/23		SIZE 紙張尺寸 A 4 REV. 版次 A	
		PART NO. 料號 W1261-XXPBTX10R	

1 2 3 4 5 6 7 8